

Welded Body Ball Valves



WELDED BODY BALL VALVES

Your Ideal Choice for Flow Control and Sealing Solutions

In a short period of 20 years, Virgo Engineers has gained a position of prominence in the field of Process Valves, Pipeline Ball Valves and Automation Systems for a host of applications in Chemical, Petrochemical, Oil & Gas, Fertilizer and Pharmaceutical industries. During this period, Virgo established its presence in the United States of America and the Middle East. The next strategic foray was into Europe to address the burgeoning market for large size ball valves and specialty products. Virgo did this by enlarging its size range and with high-end variants of ball valves. Introduction of Welded Body Ball Valves is a step in that direction.

Welded Body Ball Valves are available in the size range of 6" to 56" in pressure class ASME # 150 to # 2500. These valves are engineered to offer completely leak-proof and maintenance free solution in a most reliable and cost effective way. And as such are ideal for demanding applications in industries such as On shore / off shore platforms, Oil & Gas, LNG / LPG Storage and Transport, to name a few.

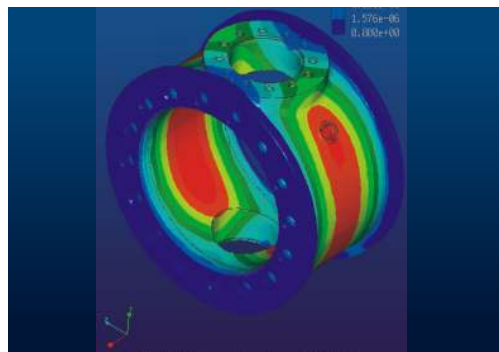

Design Features

- ◆ Welded body construction eliminates body flanges, reduces potential leak paths and increases resistance to pipeline pressure and stresses.
- ◆ Forged steel construction ensures uniform grain structure, toughness and sound weld quality.
- ◆ Engineered designs and features provide maintenance free performance.

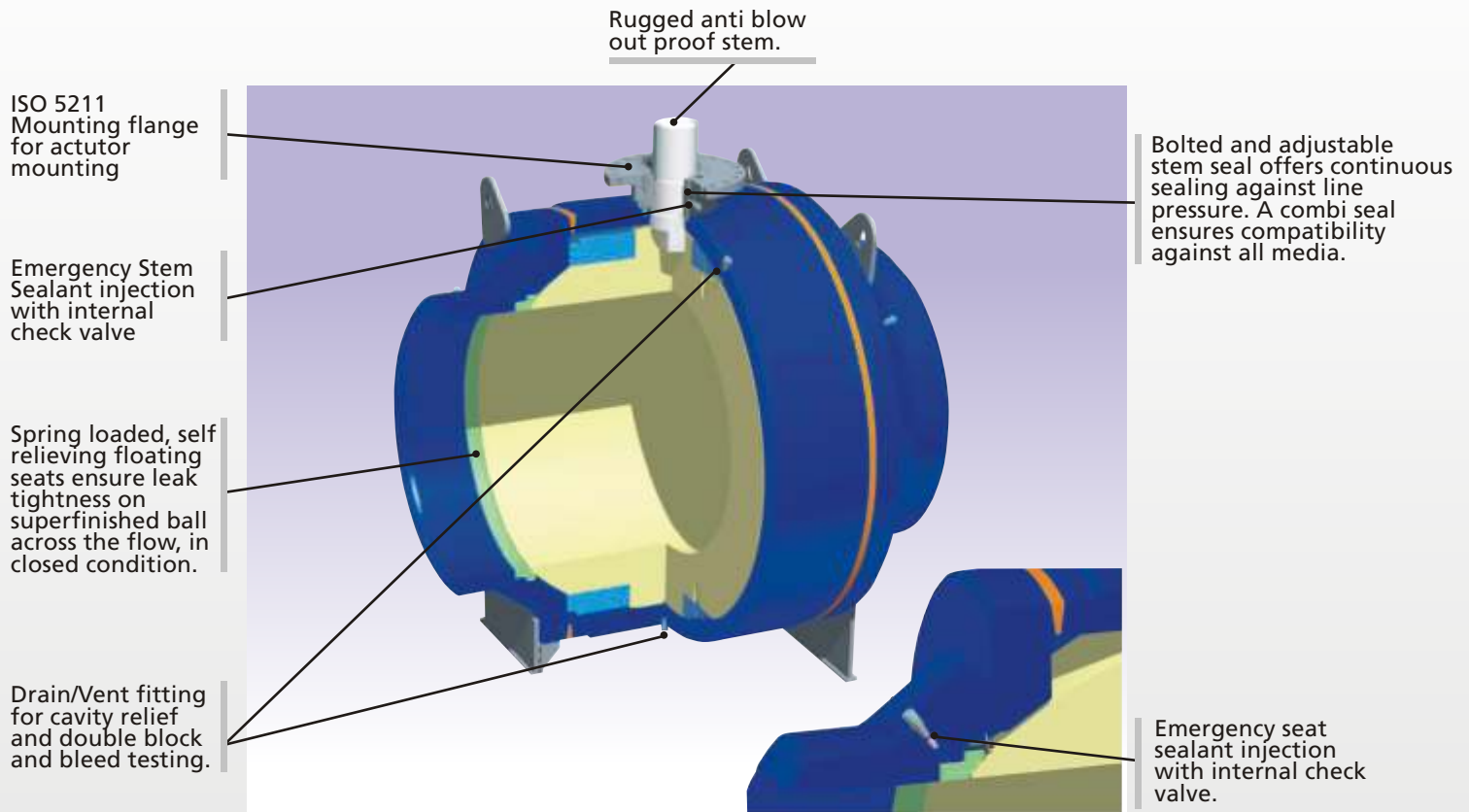

Standard :

- Double Block and Bleed
- Fire Safe design
- Anti blow out stem
- Anti-Static Device for electrical continuity
- Self lubricated bearings
- Multiple Stem Sealing for Leak Proof Joint
- Gear Operator

Optional :

- Emergency Sealant Injection
- Stem Extension
- Pipe Extension (Pup pieces)
- Corrosion Protection and painting
- Locking Arrangements
- Actuator & Accessories
- Weld Overlays

Applications

- Oil and gas product pipelines and transmission.
- Gas Storage
- Compressor Stations and Measuring Skids
- Onshore and offshore platforms
- Dehydration, dryer, gas separation systems
- Liquid gas, launch and receiving stations

Part List and Reference Standards

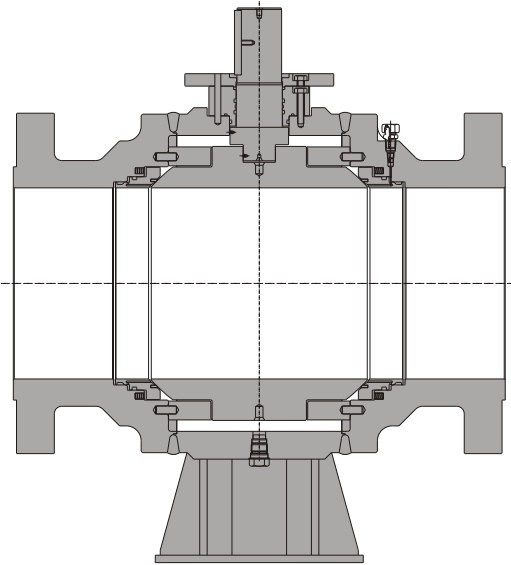

No	Description
01	Body
02	Closure
03	Seat + Insert
04	Ball
05	Stem
06	Gland Plate
07	Bearing Retainer
08	ISO Mounting Plate
10a	Seat O-ring
10c	Stem O-Ring
10d	Gland Plate O-Ring
14	Gland Plate Boltings
14	Mounting Flange Boltings
15	Seat Springs
19/20	Vent/Drain Plug
21	Ball Bearing
22	Stem Thrust Washer
23	Ball Thrust Washer

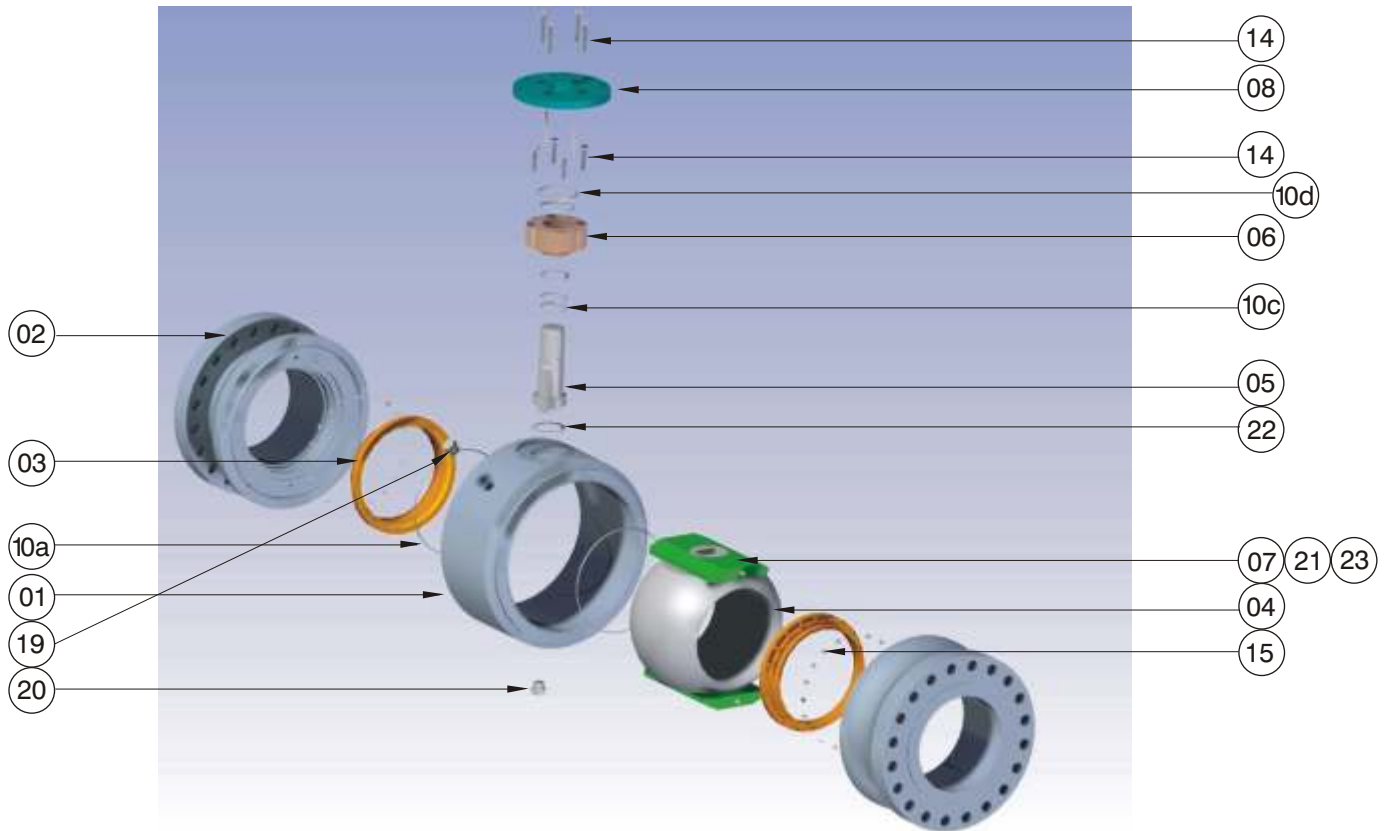

Design & Testing Standards

Design	ASME B16.34, API 6D & BS5351 / BS EN ISO 17292
Face to Face	ASME B16.10 / API 6D
Flange Dimensions	ASME B16.5 / B16.47 / MSS SP44
Butt Weld Ends	ASME B16.25 / 31.3 / 31.4 / 31.8
Pressure Test	API 6D / API 598 / BS EN 12266 PART 1 & 2
Fire Safe Test	API 607 / API 6FA / BS EN ISO 10497
Fugitive Emission Test	ISO 15848 / TA-Luft : VDI 2440 / MESC 77/312 / EPA 40_CFR 60-F
Material	NACE MR 01-75 compliant

Dimensional Details

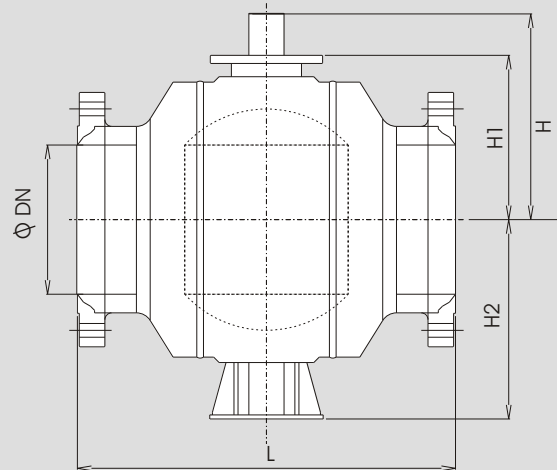

Size	ANSI Class 150						ANSI Class 300						ANSI Class 600					
	L			H	H1	H2	L			H	H1	H2	L			H	H1	H2
	RF	BWE	RTJ				RF	BWE	RTJ				RF	BWE	RTJ			
150 (6")	394	457	406	292	220	320	403	403	419	292	220	244	559	559	562	292	220	225
200 (8")	457	521	470	327	255	226	502	521	518	327	255	295	660	660	664	340	268	271
250 (10")	533	559	546	369	298	321	568	559	584	369	298	320	787	787	791	376	304	331
300 (12")	610	635	622	309	338	371	648	635	664	309	338	371	838	838	841	492	395	369
350 (14")	686	762	699	378	381	412	762	762	778	378	381	412	889	889	892	516	383	433
400 (16")	762	838	775	516	420	430	838	838	854	560	423	468	991	991	994	560	423	440
450 (18")	864	914	876	596	459	478	914	914	930	596	461	476	1092	1092	1095	614	471	520
500 (20")	914	991	927	633	500	525	991	991	1010	645	512	505	1194	1194	1200	656	512	505
600 (24")	1067	1143	1080	718	585	650	1143	1143	1165	731	594	744	1397	1397	1407	776	622	681
750 (30")	1295	1397	*	856	702	747	1397	1397	1422	881	727	798	1651	1651	1664	998	805	832
900 (36")	1524	1727	*	976	822	886	1727	1727	1756	991	837	913	2083	2083	2099	1108	915	947
1000 (40")	1600	*	*	1051	897	958	1778	*	*	1163	970	1010	2083	2083	2099	1233	1015	1062
1050 (42")	1689	*	*	1091	937	1014	1829	*	*	1203	1010	1064	2083	2083	2099	1273	1055	1102
1200 (48")	1918	*	*	1206	1052	1147	2020	*	*	1353	1135	1166	2200	2083	2216	1398	1180	1215

Size	ANSI Class 900						ANSI Class 1500						ANSI Class 2500					
	L			H	H1	H2	L			H	H1	H2	L			H	H1	H2
	RF	BWE	RTJ				RF	BWE	RTJ				RF	BWE	RTJ			
150 (6")	610	610	613	302	231	245	705	705	711	374	283	452	914	914	927	419	332	385
200 (8")	737	737	740	373	276	277	832	832	841	459	362	535	1022	1022	1038	509	413	470
250 (10")	838	838	841	425	332	336	991	991	1000	477	367	407	1270	1270	1292	542	487	545
300 (12")	965	965	968	475	363	365	1130	1130	1146	573	419	455	1422	1422	1445	614	559	620
350 (14")	1029	1029	1038	612	444	565	1257	1257	1276	683	515	476	-	-	-	-	-	-
400 (16")	1130	1130	1140	626	483	530	1384	1384	1407	681	527	551	-	-	-	-	-	-
450 (18")	1219	1219	1232	661	507	554	1537	1537	1559	815	645	673	-	-	-	-	-	-
500 (20")	1321	1321	1334	706	552	603	1664	1664	1686	878	685	690	-	-	-	-	-	-
600 (24")	1549	1549	1568	893	700	727	-	-	-	-	-	-	-	-	-	-	-	-
750 (30")	1880	1880	1902	1028	835	860	-	-	-	-	-	-	-	-	-	-	-	-
900 (36")	2240	2240	2269	1193	975	999	-	-	-	-	-	-	-	-	-	-	-	-

Note : All dimensions are in mm
 Valve Bore (ØDN) as per API 6D
 For * marked dimensions consult Virgo
 Dimensions for 50", 52", 54" and 56" will be provided on request

Pressure Temperature Ratings

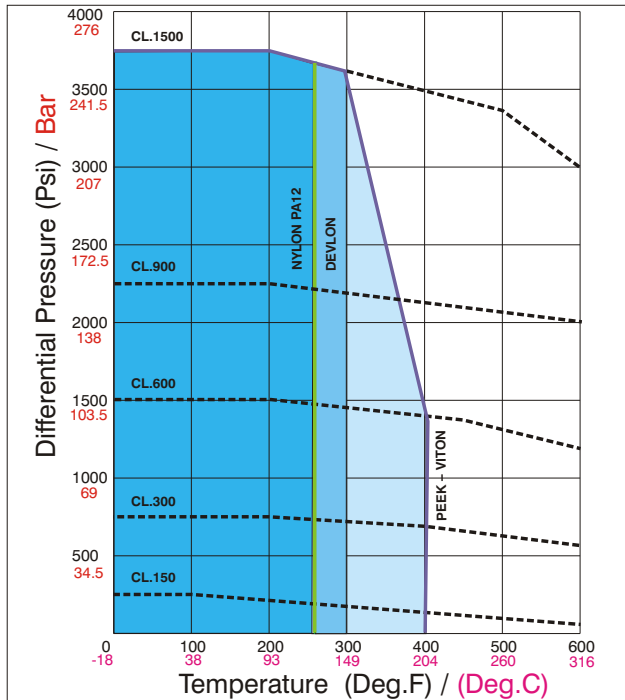

Pressure - temperature seat ratings of valves are as given in the graph for body material A 216 - WCB.

All pressure containing parts comply to the pressure temperature ratings as specified in ANSI B 16.34

Temperature Limits:

Typical values for few materials

		Lower limit		Upper limit *	
		Deg.F/Deg.C		Deg.F/Deg.C	
Body Matl.	WCB	(-20)	(-29)	800	425
	LCB	(-50)	(-46)	650	345
	CF8	(-425)	(-254)	1000	538
Seat	NYLON	(-50)	(-46)	As per Graph	
	DEVLON	(-50)	(-46)	As per Graph	
	PEEK	(-50)	(-46)	As per Graph	

* Useful application limit.

For applications above 400°F (204°C) consult Virgo
Other ratings on request.

Metal to metal seats are also supplied on request

Note : These ratings are a guide for general service.
Please consult Virgo for specific recommendations.

Special Options

Sealant Injection System

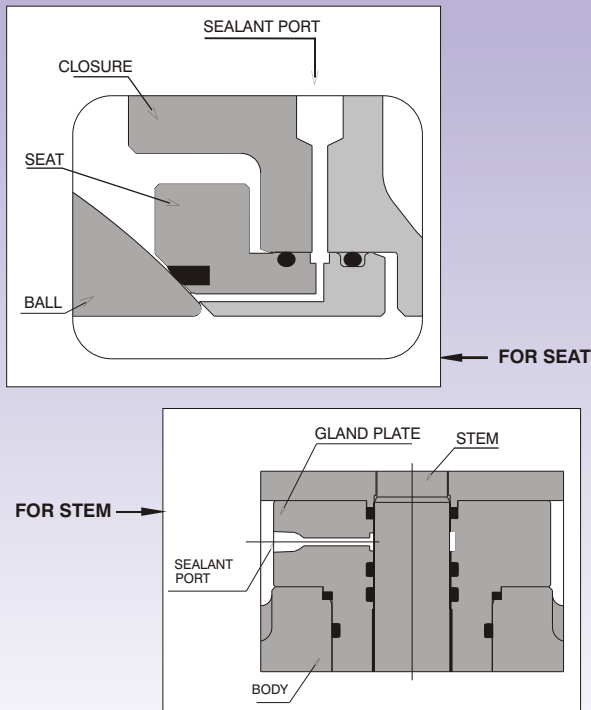

For stem sealing, additional gland security is available using stem sealant injection system. Similarly in the event of seat face damage due to contamination, an emergency seal can be formed using a seat sealant injection facility.

Stem Extension / Extended Gear Operator

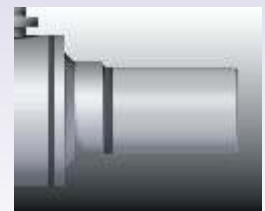

Valve can be offered with stem, bleed & sealant injection line extensions when used for underground installations. Also available for butt weld valves are transition pieces (PUPS) to avoid any risk of seal damage during installation.

PRODUCT SELECTION CODE

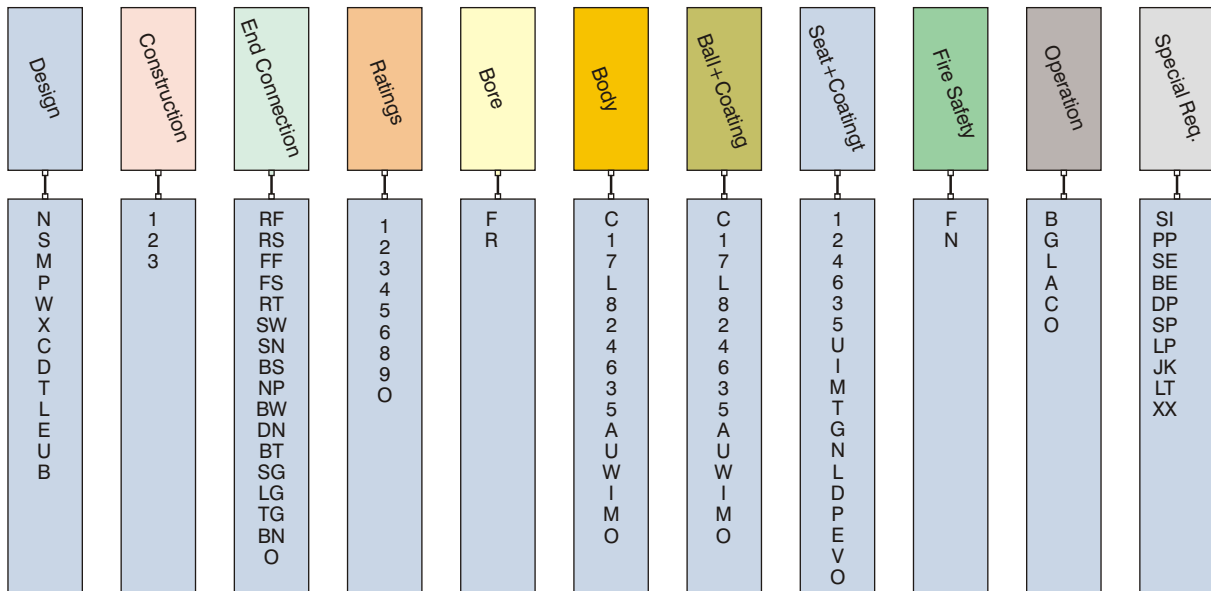

Design	Ratings	Seat
N - Side Entry Soft Seated Trunnion	1 - 150# / PN16	1 - A105
S - Side Entry Soft Seated Floater	2 - 1500#	2 - LF2
M - Side Entry Metal Seated Trunnion	3 - 300# / PN40	4 - F304
P - Side Entry Metal Seated Floater	4 - 400# / PN64	6 - F316
W - Side Entry Welded Body Trunnion	5 - 2500#	3 - F304L
X - Side Entry Welded Body Floater	6 - 600#	5 - F316L
C - Side Entry Cryogenic Trunnion	8 - 800#	U - Duplex SS
D - Side Entry Cryogenic Floater	9 - 900#	I - Inconel
T - Side Entry Multi Port (T Port)	O - Other than above	M - Monel
L - Side Entry Multi Port (L Port)		T - PTFE
E - Top Entry Soft Seated Trunnion		G - RPTFE
U - Top Entry Metal Seated Trunnion		N - Nylon-PA 12
B - Top Entry Cryogenic Trunnion		L - Nylon-Devlon
		D - Delrin
		P - PEEK
		E - PCTFE
		V - VITON
		O - Other than above
		Fire Safety
		F - Fire Safe
		N - Non-Fire Safe
		Operator
		B - Bare Stem
		G - Gear
		L - Hand Lever
		A - Actuated
		C - Chain Wheel
		O - Other than above
		Special Requirement
		SI - Sealant Injection
		PP - Pup Piece
		SE - Stem Extension
		BE - Bonnet Extension
		DP - Double Piston Effect (Non Relieving)
		SP - Short Pattern
		LP - Long Pattern
		JK - Jacketed
		LT - Low Temp. (-46 ^ C / -50 ^ F)
		XX - Special Requirement To Be Specified
	Bore	
	F - Full	
	R - Reduced / Regular	
	Body & Ball	
	C - WCB	
	1 - A105	
	7 - WCC	
	L - LCB	
	8 - LF2	
	2 - LCC	
	4 - CF8 / SS304 / F304	
	6 - CF8M / SS316 / F316	
	3 - CF3 / SS	
	5 - CF3M / SS316L / F316L	
	A - CA 15 / SS 410 / F6A	
	U - Duplex SS	
	W - Super Duplex	
	I - Inconel	
	M - Monel	
	O - Other than above	
	Ball/Seat Coating (If applicable)	
	e - ENP	
	w - Overlay	
	h - Hard Chrome	
	s - Stellite	
	c - Chrome Carbide	
	t - Tungsten Carbide	
	n - Chromium Nitride	
	O - Other than above	

Example



Above stands for Side Entry Welded Body Soft Seated Trunnion, Three piece body, Butt Weld ends, 900#, Full Bore, A105 Body, A105 Ball with ENP coating, Nylon seat, Fire safe, Gear Operated, Bonnet extension with Sealant injection facility.



Virgo, Europe



Virgo, India



Virgo, USA

VIRGO EUROPE SpA.

Via Torino 3/5, 20039, Varedo, Milano (Italy)

Phone : +39 0362 589711

Fax : +39 0362 554439

E-mail : scalciolari@virgoeurope.com

VIRGO ENGINEERS INC.

13219, N. Promenade Blvd., Stafford,

Texas 77477, USA

Phone : +1 281 491 0400 Fax : +1 281 491 0444

E-mail : mmalkarnekar@virgoengineers.com

VIRGO ENGINEERS LIMITED / VIRGO VALVES & CONTROLS LIMITED

277, Hinjewadi Phase II, Maan (Mulshi), Pune - 411 057, India

Phone : +91 20 66744000 Fax : +91 20 66744021

E-mail : sales@virgoengineers.com

VIRGO VALVES & CONTROLS LIMITED (Warehouse & Valve Automation Centre)

Unit - FZS1 AH07, Jebel Ali Free Zone (South),

P. O. Box 18748, Dubai - UAE

Phone : +971 4 8860980, Fax : +971 4 8860981

E-mail : salesuae@virgoengineers.com

VIRGO VALVES & CONTROLS LIMITED

Suite 1904, 19th floor, Kenanga International,

Jalan Sultan Ismail, 50250 Kuala Lumpur, Malaysia.

Phone : +60 3 2161 8260 Fax : + 60 3 2166 6489

E-mail : ajagnade@virgoengineers.com

BRANCH OFFICES IN INDIA :

● Mumbai : Tel : (022) 40110700 Fax : (022) 40110701

● New Delhi : Tel : (11) 41729161-63 Fax : (011) 41729164

● Kolkata : Tel : (033) 22272269, (033) 22272533 Fax : (033) 22272279

● Chennai : Tel : (044) 24404119 Fax : (044) 24410664

● Vadodara : Tel : (0265) 2342837, (0265) 2341053, (0265) 2355133 Fax : (0265) 2314449

Specifications subject to change